

# E6A2-C

## Compact Encoder with External Diameter of 25 mm

- Incremental model
- External diameter of 25 mm.
- Resolution of up to 500 ppr.



 Be sure to read *Safety Precautions* on page 3.

### Ordering Information

**Encoders** [Refer to *Dimensions* on page 4.]

Power supply voltage	Output configuration	Output phases	Resolution (pulses/rotation)	Model
5 to 12 VDC	Voltage output	Phases A, B, and Z	100, 200, 360	<b>E6A2-CWZ3E (resolution) 0.5M</b> Example: E6A2-CWZ3E 100P/R 0.5M
	Open-collector output (NPN output)		500	<b>E6A2-CWZ3C (resolution) 0.5M</b> Example: E6A2-CWZ3C 100P/R 0.5M
12 to 24 VDC			100, 200, 360	<b>E6A2-CWZ5C (resolution) 0.5M</b> Example: E6A2-CWZ5C 100P/R 0.5M
	500			
5 to 12 VDC	Voltage output	Phases A and B	100, 200, 360	<b>E6A2-CW3E (resolution) 0.5M</b> Example: E6A2-CW3E 100P/R 0.5M
	Open-collector output (NPN output)		500	<b>E6A2-CW3C (resolution) 0.5M</b> Example: E6A2-CW3C 100P/R 0.5M
12 to 24 VDC			100, 200, 360	<b>E6A2-CW5C (resolution) 0.5M</b> Example: E6A2-CW5C 100P/R 0.5M
	500			
5 to 12 VDC	Voltage output	Phase A	10, 20, 60, 100, 200, 300, 360	<b>E6A2-CS3E (resolution) 0.5M</b> Example: E6A2-CS3E 10P/R 0.5M
	Open-collector output (NPN output)		500	<b>E6A2-CS3C (resolution) 0.5M</b> Example: E6A2-CS3C 10P/R 0.5M
12 to 24 VDC			10, 20, 60, 100, 200, 300, 360	<b>E6A2-CS5C (resolution) 0.5M</b> Example: E6A2-CS5C 10P/R 0.5M
	500			

**Accessories (Order Separately)** [Refer to *Dimensions* on *Rotary Encoder Accessories*.]

Name	Model	Remarks
Coupling	<b>E69-C04B</b>	Provided with the product.
Servo Mounting Bracket	<b>E69-1</b>	Provided with the E6A2-CWZ□.

Refer to *Accessories* for details.

## Ratings and Specifications

Item	Model	E6A2-CWZ3E	E6A2-CWZ3C	E6A2-CWZ5C	E6A2-CW3E	E6A2-CW3C	E6A2-CW5C	E6A2-CS3E	E6A2-CS3C	E6A2-CS5C
Power supply voltage		5 VDC -5% to 12 V +10% ripple (p-p): 5% max.		12 VDC -10% to 24 VDC +15%, ripple (p-p): 5% max.	5 VDC -5% to 12 V +10%, ripple (p-p): 5% max.		12 VDC -10% to 24 VDC +15%, ripple (p-p): 5% max.	5 VDC -5% to 12 V +10%, ripple (p-p): 5% max.		12 VDC -10% to 24 VDC +15%, ripple (p-p): 5% max.
Current consumption*1		50 mA max.	30 mA max.		30 mA max.	20 mA max.		30 mA max.	20 mA max.	
Resolution (pulses/rotation)		100, 200, 360, 500						10, 20, 60, 100, 200, 300, 360, 500		
Output phases		Phases A, B, and Z			Phases A and B			Phase A		
Output configuration		Voltage output	NPN open-collector output		Voltage output	NPN open-collector output		Voltage output	NPN open-collector output	
Output capacity		Output resistance: 2 kΩ Output current: 20 mA max. Residual voltage: 0.4 V max. (Output current: 20 mA max.)	Applied voltage: 30 VDC max. Sink current: 30 mA max. Residual voltage: 0.4 V max. (at sink current of 30 mA)		Output resistance: 2 kΩ Output current: 20 mA max. Residual voltage: 0.4 V max. (Output current: 20 mA max.)	Applied voltage: 30 VDC max. Sink current: 30 mA max. Residual voltage: 0.4 V max. (at sink current of 30 mA)		Output resistance: 2 kΩ Output current: 20 mA max. Residual voltage: 0.4 V max. (Output current: 20 mA max.)	Applied voltage: 30 VDC max. Sink current: 30 mA max. Residual voltage: 0.4 V max. (at sink current of 30 mA)	
Maximum response frequency*2		30 kHz								
Phase difference between outputs		Phase difference between phases A and B: 90°±45°						---		
Output duty factor		---						50±25%		
Rise and fall times of output		1.0 μs max. (Cable length: 500 mm, Sink current: 10 mA)	1.0 μs max. (Cable length: 500 mm, Control output voltage: 5 V, Load resistance: 1 kΩ)		1.0 μs max. (Cable length: 500 mm, Sink current: 10 mA)	1.0 μs max. (Cable length: 500 mm, Control output voltage: 5 V, Load resistance: 1 kΩ)		1.0 μs max. (Cable length: 500 mm, Sink current: 10 mA)	1.0 μs max. (Cable length: 500 mm, Control output voltage: 5 V, Load resistance: 1 kΩ)	
Starting torque		1 mN·m max.								
Moment of inertia		1 × 10 <sup>-7</sup> kg·m <sup>2</sup> max.								
Shaft loading	Radial	10 N								
	Thrust	50 N								
Maximum permissible speed		5,000 r/min								
Ambient temperature range		Operating: -10 to 55°C (with no icing), Storage: -25 to 80°C (with no icing)								
Ambient humidity range		Operating/storage: 35% to 85% (with no condensation)								
Insulation resistance		20 MΩ min. (at 500 VDC) between current-carrying parts and case								
Dielectric strength		500 VAC, 50/60 Hz for 1 min between current-carrying parts and case								
Vibration resistance		Destruction: 10 to 55 Hz, 1.5-mm double amplitude for 2 hours each in X, Y, and Z directions								
Shock resistance		Destruction: 500m/s <sup>2</sup> 3 times each in X, Y, and Z directions								
Degree of protection*3		IEC 60529 IP50								
Connection method		Pre-wired Models (Standard cable length: 500 mm)								
Material		Case: Aluminum alloy, Main unit: Aluminum, Shaft: SUS420J2, Mounting Bracket: Galvanized iron								
Weight (packed state)		Approx. 35 g								
Accessories		Coupling, Servo Mounting Bracket (provided with the E6A2-CWZ□□), Hexagonal wrench, Instruction manual								

\*1. An inrush current of approximately 9 A will flow for approximately 0.3 ms when the power is turned ON.

\*2. The maximum electrical response speed is determined by the resolution and maximum response frequency as follows:

$$\text{Maximum electrical response speed (rpm)} = \frac{\text{Maximum response frequency}}{\text{Resolution}} \times 60$$

This means that the E6A2-C Rotary Encoder will not operate electrically if its speed exceeds the maximum electrical response speed.

\*3. No protection is provided against water or oil.

I/O Circuit Diagrams

Model	Output circuits	Output mode	Connection												
E6A2-CS3C E6A2-CS5C	<p>E6A2 main circuit</p> <p>Brown <math>V_{CC}</math> (+5 to 12 V) (E6A2-C□□3C: +5 to 12 V) (E6A2-C□□5C: +12 to 24V)</p> <p>Black, white, orange Output (Black: phase A, White: phase B, Orange: phase Z)</p> <p>Blue 0 V</p> <p>30 VDC 30 mA max.</p>	Output transistor	<table border="1"> <thead> <tr> <th>Color</th> <th>Signal</th> </tr> </thead> <tbody> <tr> <td>Brown</td> <td><math>V_{CC}</math></td> </tr> <tr> <td>Black</td> <td>Phase A</td> </tr> <tr> <td>White</td> <td>Phase B</td> </tr> <tr> <td>Orange</td> <td>Phase Z</td> </tr> <tr> <td>Blue</td> <td>0 V (common)</td> </tr> </tbody> </table> <p>Note: 1. The white and orange wires of Single Models (E6A2-CS□□) do not output signals (no connection). 2. The white and orange wires of Single Models (E6A2-C□□□) do not output signals (no connection). 3. Voltage Output Models are capable of sinking a maximum current of 20 mA.</p>	Color	Signal	Brown	$V_{CC}$	Black	Phase A	White	Phase B	Orange	Phase Z	Blue	0 V (common)
Color		Signal													
Brown		$V_{CC}$													
Black	Phase A														
White	Phase B														
Orange	Phase Z														
Blue	0 V (common)														
E6A2-CW3C E6A2-CW5C	Direction of rotation: CW (as viewed from end of shaft)	Output transistor													
E6A2-CWZ3C E6A2-CWZ5C	Direction of rotation: CCW (as viewed from end of shaft)	Output transistor													
E6A2-CW3E	<p>E6A2 main circuit</p> <p>Brown <math>V_{CC}</math> (+5 to 12 V)</p> <p>Black, white, orange Output (Black: phase A, White: phase B, Orange: phase Z)</p> <p>Blue 0 V</p> <p>20 mA max.</p> <p>2 kΩ</p>	Output transistor													
E6A2-CWZ3E		Output transistor													
E6A2-CS3E		Output transistor													

Note: 1. \*(H) and (L) indicate the output levels of Voltage Output Models.  
2. Output A leads B by  $1/4 T \pm 1/8 T$  when the shaft revolves clockwise, while A lags behind B by  $1/4 T \pm 1/8 T$  when the shaft revolves counterclockwise.

Safety Precautions

Refer to *Warranty and Limitations of Liability*.

**⚠ WARNING**

This product is not designed or rated for ensuring safety of persons either directly or indirectly. Do not use it for such purposes.



**Precautions for Correct Use**

Do not use the Encoder under ambient conditions that exceed the ratings.

● **Wiring**

Spurious pulses may be generated when power is turned ON and OFF. Wait at least 0.1 s after turning ON the power to the Encoder before using the connected device, and stop using the connected device at least 0.1 s before turning OFF the power to the Encoder. Also, turn ON the power to the load only after turning ON the power to the Encoder.

(Unit: mm)

## Dimensions

Tolerance class IT16 applies to dimensions in this datasheet unless otherwise specified.

## Encoder

### E6A2-C

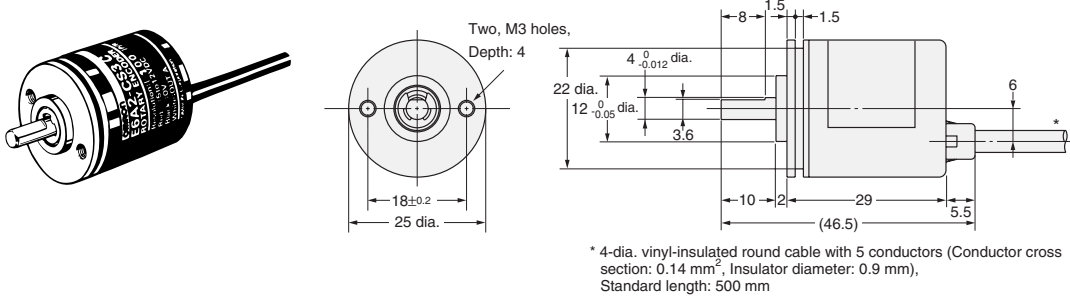

## Accessories (Order Separately)

**Coupling**

**Servo Mounting Bracket**

**E69-C04B**

**E69-1**

Refer to *Accessories* for details.